

American Safe Room

Explosion Resistant Blast Hatch with Integrated Riser

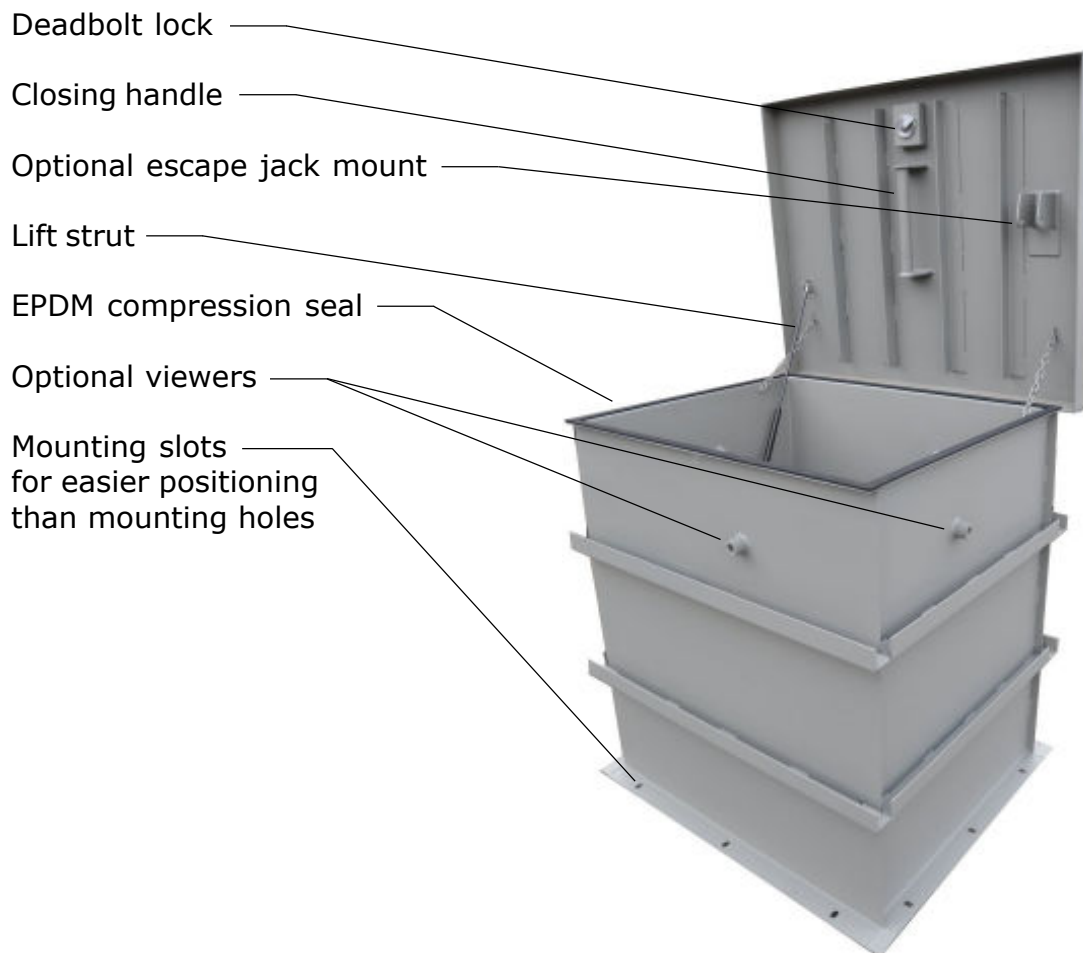

Drawing: ASR-50-RBH
Revision: G
November 16, 2011

Table of Contents

Description	3
Options	4
Order form	5
Option: left or right hand hatch	6
Option: viewers	7
Option: emergency escape jack	8
Option: external ladder extension	9
Option: internal ladder assembly	10
Calculating the height of the first rung from the floor	10
Dimensional constraints	11
Installation	12
Mounting the riser on an American Safe Room shelter	13
Mounting the riser on a conventional concrete shelter	14
Installing the internal ladder assembly	15
Installing the concrete wedge anchors	16

**COPYRIGHT ©2011 LEONARD M. HENRIKSON, ALL RIGHTS RESERVED
THE DRAWINGS AND TEXT IN THIS MANUAL ARE COPYRIGHTED MATERIAL**

Description

The ASR-50-RBH Riser Blast Hatch is designed to be installed on an underground shelter. It features an integrated riser that can be ordered in custom heights to match the backfill depth of the shelter.

It is supplied with a coat of shop primer and includes concrete wedge anchors for mounting it on the roof of a concrete shelter.

The blast lid is constructed from ASTM A-36 steel plate laterally reinforced by 4 stress resistant steel bars. It is designed to withstand a 7,200 pound per square foot (50 PSI) blast load or a 1,500 pound point load. It uses a gas lift cylinder to assist the opening. The riser tunnel is also constructed from ASTM A-36 steel plate with strategically placed reinforcement stiffeners.

The hinge assembly is the same massive one used on our ASR-50-BD Blast Doors. It features bronze bushings, grease zerks, and an inch and half 1018 alloy steel pin.

The two inner latches are cam operated compression latches that compress the EPDM seal.

The external heavy duty dead bolt cylinder style key lock has a steel external weather guard constructed from ASTM A53 grade A steel.

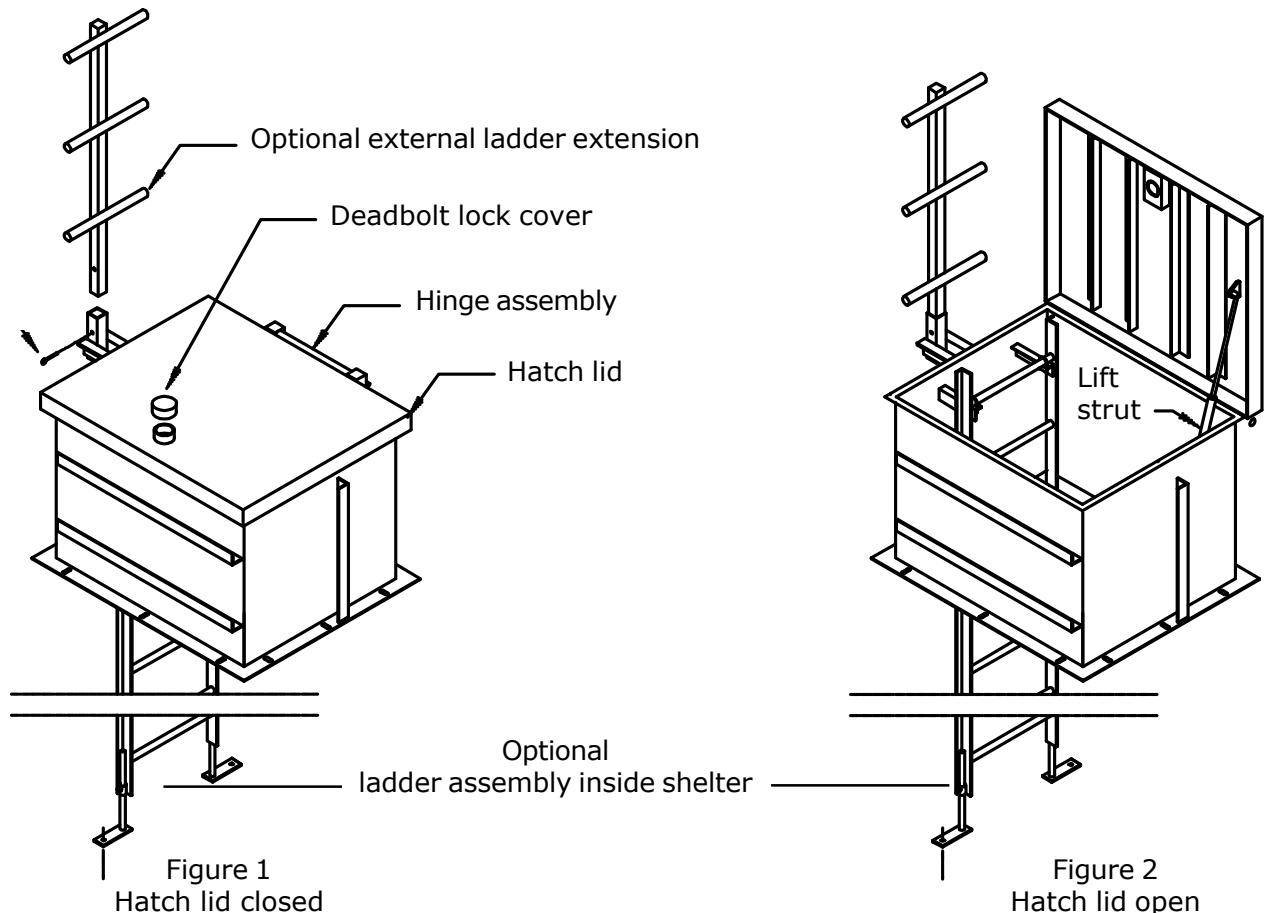

Options

Optional Viewers

The riser hatch can be supplied with a “peep sight” wide angle viewer strategically mounted on each of the four walls. They are mounted six inches below the hatch. This gives you the ability to see what is directly around your hatch before opening it.

Optional emergency escape jack

This 3 ton bottle jack can be deployed if trees fall on top of your hatch. In the stowed position, it nests down behind the ladder. It must be rotated up into position before use - but you do not have to climb a ladder with a jack to deploy it.

Optional external ladder extension

The riser hatch can be ordered with a removable above ground extension ladder for assistance and added safety for personnel entering or exiting the shelter. It fits into a socket welded onto the outside of the riser.

Optional internal ladder assembly

The riser hatch may be ordered with a bolt on ladder assembly. This heavy duty steel ladder is rated for 300 pounds. It is built to order so it fits your shelter with the proper dimensions — the bottom rung is between 6 and 12 inches off the floor, the top rung is 6 inches from the top of the riser, and all the rungs in between are 12 inches apart with the proper toe clearance from the wall. See page 5 for ordering details.

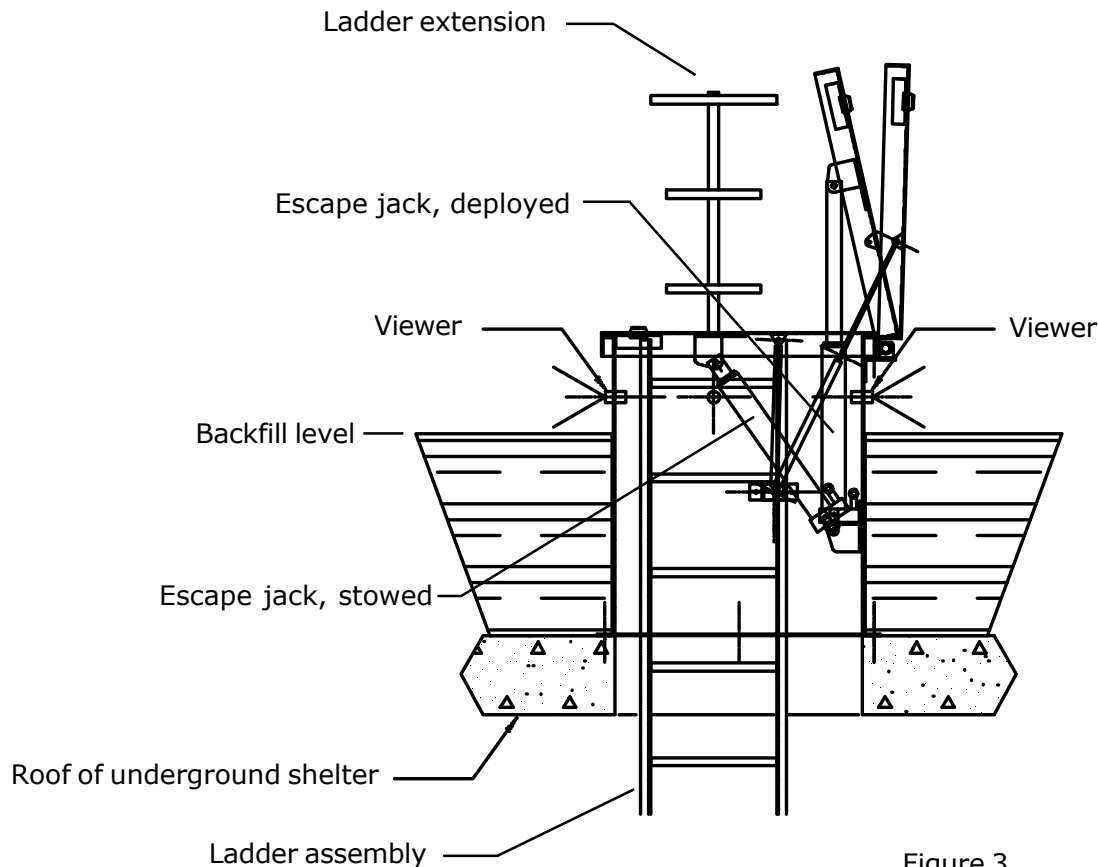
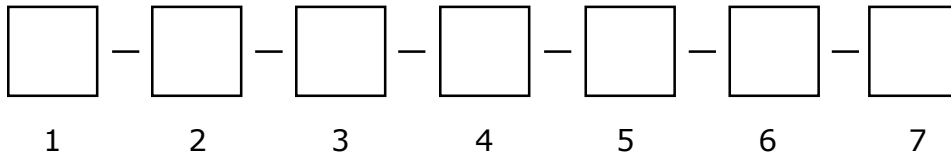

Figure 3
Viewers, jack, and ladder extension

Ordering your hatch ladder system

Generate the part number that will be used to build your hatch:



1. Left hand or right hand hatch - see page 6. Enter L or R.
2. Z1 dimension, height of riser - see below. Enter height in inches.
3. Z2 dimension, total height of shelter - see below. Enter height in inches.
Please note: this dimension is only needed if you are ordering the optional internal ladder assembly - box 7.
4. Viewers - see page 7 - also see curb height below. Enter Y or N.
5. Integrated emergency escape jack - see page 8. Enter Y or N.
6. External ladder extension - see page 9. Enter Y or N.
7. Internal ladder assembly - see page 10. Enter Y or N.

Example: (L-32-88-Y-N-Y-N-N) is a left hand hatch with viewers, without an external deadbolt lock, with the emergency jack, and without any ladders.

Note — see dimensional constraints on page 11 before generating your part number.

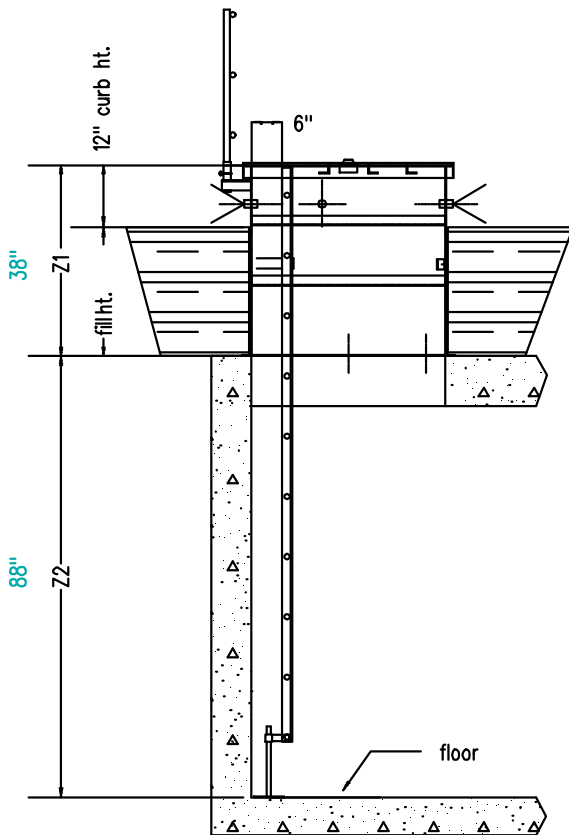

Figure 4
12 inch curb height
for hatch with optional viewers

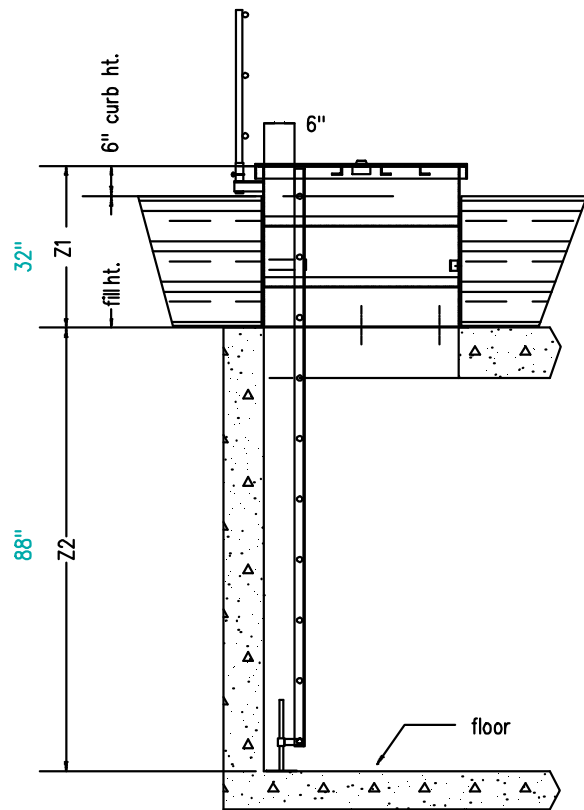

Figure 5
6 inch curb height
for hatch without optional viewers

Left hand or right hand hatch

Left hand hatch

As you face the hatch, the lift strut is on your left, the optional ladders are on your right. The optional emergency escape jack stows behind the internal ladder.

Right hand hatch

As you face the hatch, the lift strut is on your right, the optional ladders are on your left. The optional emergency escape jack stows behind the internal ladder.

In box 1 on page 5, enter "L" for a left hand hatch or "R" for a right hand hatch.

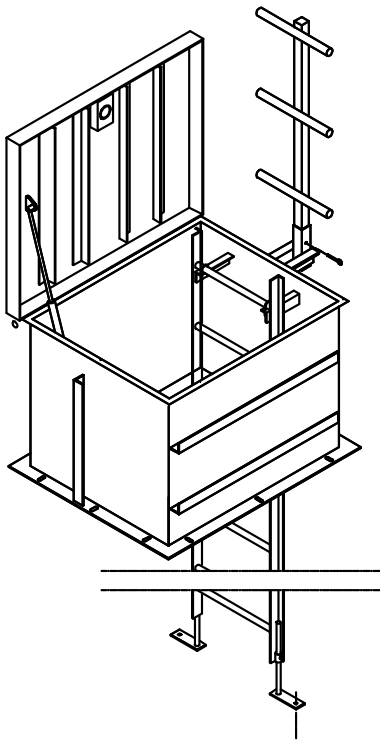

Figure 6
Left hand hatch

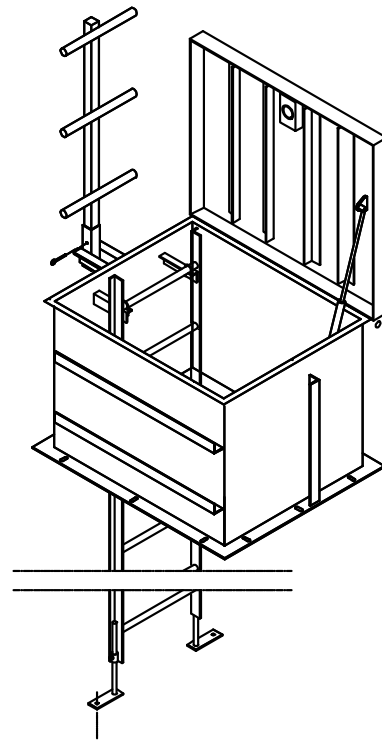

Figure 7
Right hand hatch

Viewers

This option will give you four wide angle optical viewers — one mounted on each wall of the hatch. They are located 6 inches from the bottom of the hatch lid, centered on the front and back walls, and slightly offset on the side walls. These “fish eye” viewers feature optical glass lenses and are UL listed for use on fire doors rated up to 1½ hours.

The viewers require a curb height of 12 inches so that the viewers are above ground level. See figures 4 and 5 on page 5 that show this curb height.

In box 4 on page 5, enter “Y” if you want viewers and “N” if you do not.

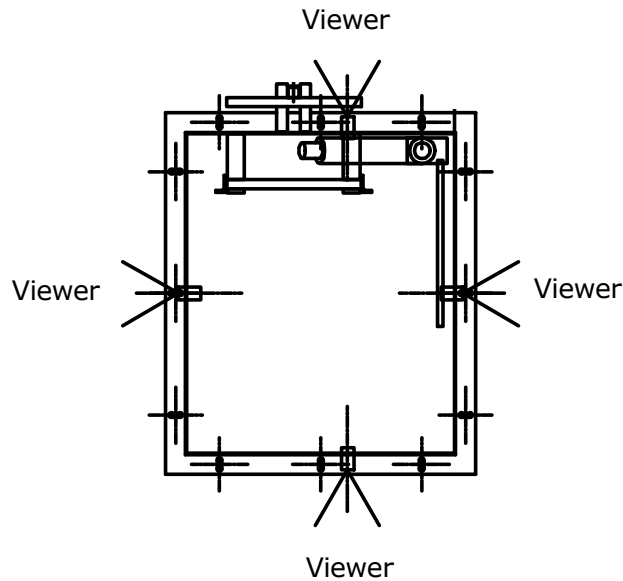

Figure 8
Viewer positions - top view

Emergency escape jack

The optional emergency escape jack will allow you to manually open the hatch lid if something heavy is dropped onto the top of your hatch like debris.

When not in use, the stowed position of the jack is behind the ladder. It must be rotated up into the deployed position and a pin inserted through the top anchor point and the jack shaft before use.

In box 5 on page 5,
enter "Y" if you want this option
and "N" if you do not.

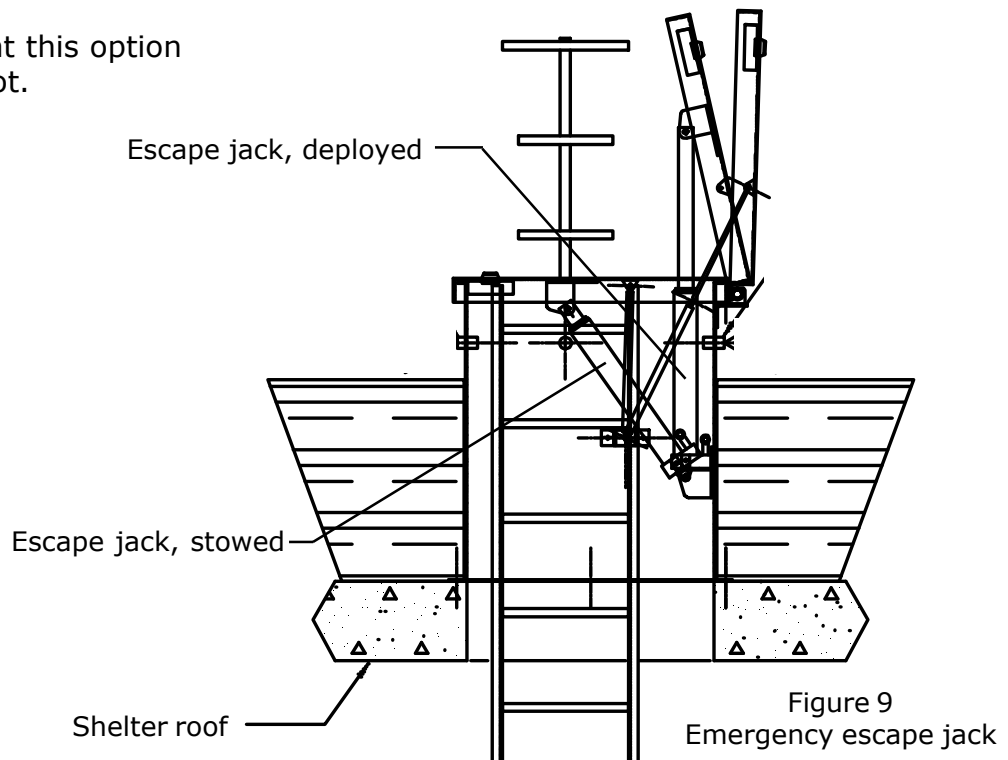

Emergency escape jack operation

1. Remove jack handle from behind the second ladder rung
2. Close the bleed valve at base of jack
3. Remove the clevis pin from ram shaft
4. Place the ram shaft into upper anchor alignment by pumping the jack handle
5. Replace the clevis pin
6. Operate the handle to jack open the hatch

Caution

The rating of the jack is 3 tons under optimal conditions, but the load location on the top of the hatch lid may reduce this rating. Also - 3 tons of pressure will deform the top lid. This jack is to be used only in an emergency as the top lid may be damaged.

Please note

The jack ram hole location in its stowed position is designed to be at rest a distance of 1.1/2" lower than the anchor hole location. This is a safety precaution in order to help insure proper clevis pin placement in cases where the top lid may be potentially distorted due to heavy falling debris. Distortion may occur during jacking in cases where extremely heavy debris has come to rest on the hatch lid.

External ladder extension

The external ladder extension assists with entering or exiting the hatch by allowing a stable hand hold above the top level of the hatch.

It can stow inside the shelter and be brought up when needed. It fits into a socket that is welded to the side of the hatch with a capture pin.

In box 6 on page 5, enter "Y" if you want this option and "N" if you do not.

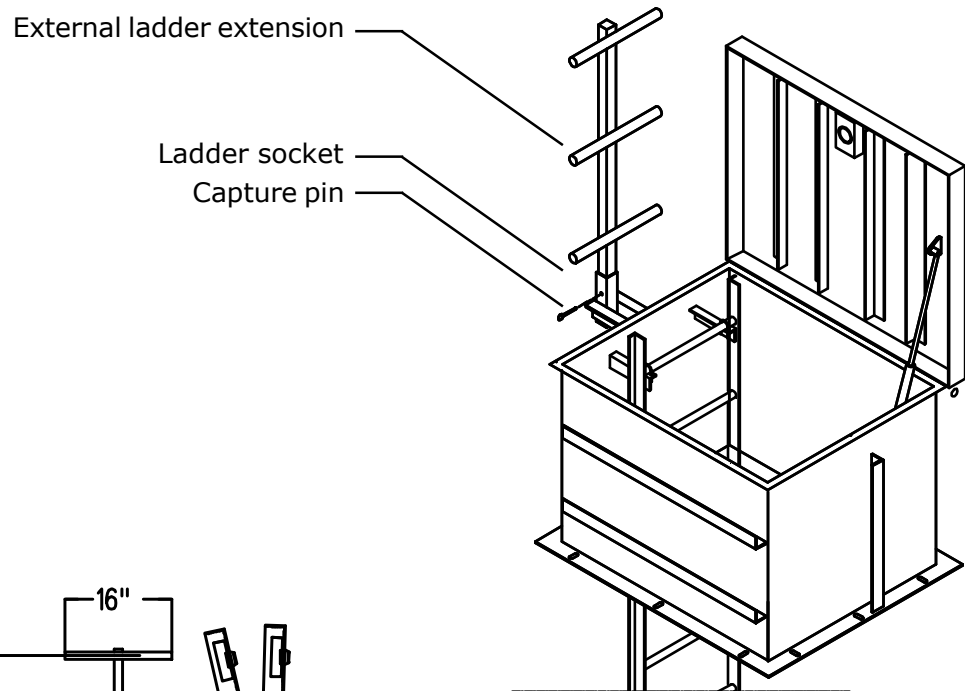

Figure 10
External ladder assembly

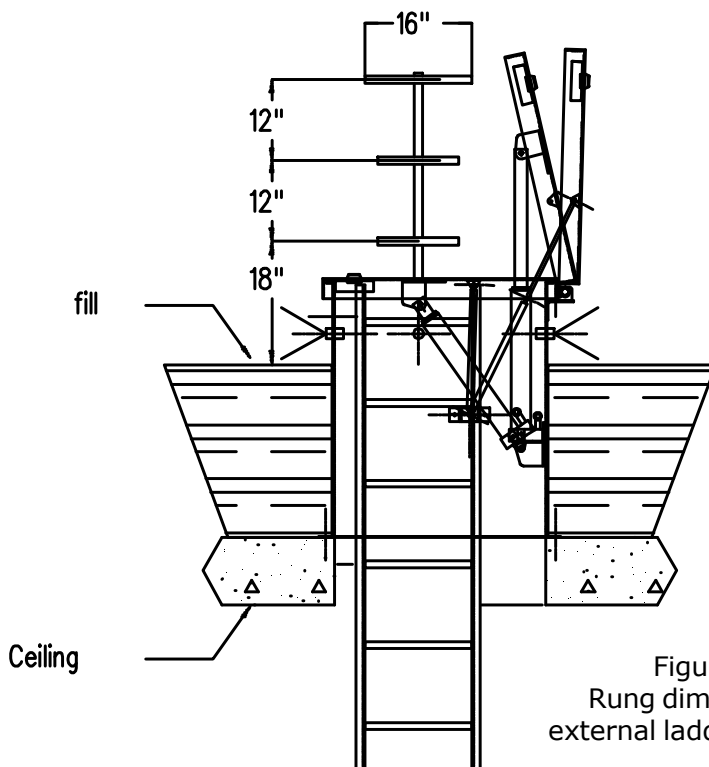

Figure 11
Rung dimensions of
external ladder extension

Internal ladder assembly

The ladder assembly mounts to the inside of the hatch and the floor of the shelter.

Please note: this ladder has a rung every 12 inches to comply with building codes. Since shelters come in all different heights, the footer assembly that connects the ladder to the floor is adjustable. This will make the bottom rung between 2 and 10 inches off of the floor. We have included the calculations for determining the height of the ladder and the height from the floor to the bottom rung on pages 16 and 17.

The dimension from the top of the hatch to the first rung is set at 6 inches. The dimensions between each rung is set at 12 inches. The dimension from the floor to the first rung is variable between 6 and 12 inches.

The height of the riser (Z1, page 5) and the height of the shelter from the floor to the **top** of the ceiling (Z2, page 5) are used to determine the ladder height, number of rungs, and the height of the first rung off of the floor. See figure 4 and 5 on page 5 for where these dimensions are taken.

In box 7 on page 5, enter "Y" if you want this option and "N" if you do not.

Calculating the height of the first rung from the floor

This example uses several variables:

DO = distance, floor to top opening + Z1 + Z2

TD = distance, required for top clearance 6", (fixed dimension)

BD = distance, required for bottom clearance = 2 inches, (fixed dimension)

OC = distance, overall top and bottom clearances TD + BD = 8" (fixed dimension)

RC = ladder rung count $DO - OC / 12 + 1$ (rung) - BD

Example:

To calculate a ladder rung count for a DO distance of 146"

$146" - 8" = 138" / 12" = 11.5 + 1$ (rung) = 12.5 rungs

To convert the decimal to actual bottom clearance from first rung center to floor.

Multiply the decimal by 12 + (BD) 2 inches

$0.5 \times 12 = 6" + 2" = 8"$ actual clearance from first rung center to floor.

Result:

A 12 rung ladder with an 8 inch clearance distance from the floor to the 1st rung center.

Dimensional constraints

The minimum height of a riser hatch (Z1 dimension) that includes a lift strut is 6 inches. The minimum height of a riser hatch (Z1 dimension) that includes the optional bottle jack is 28 inches. The maximum height of a riser hatch (Z1 dimension) is 43 inches. The largest hole size that a riser hatch can be mounted on is 32 by 38 inches.

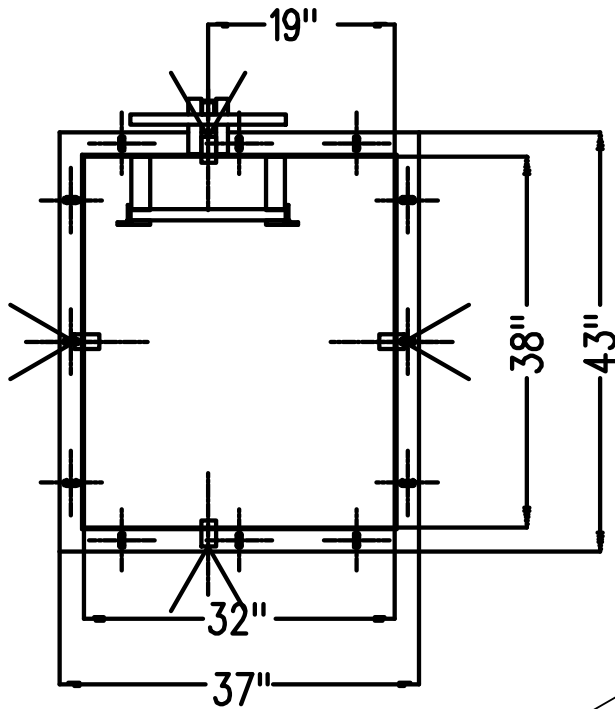

Figure 12
Footprint and
free opening dimensions

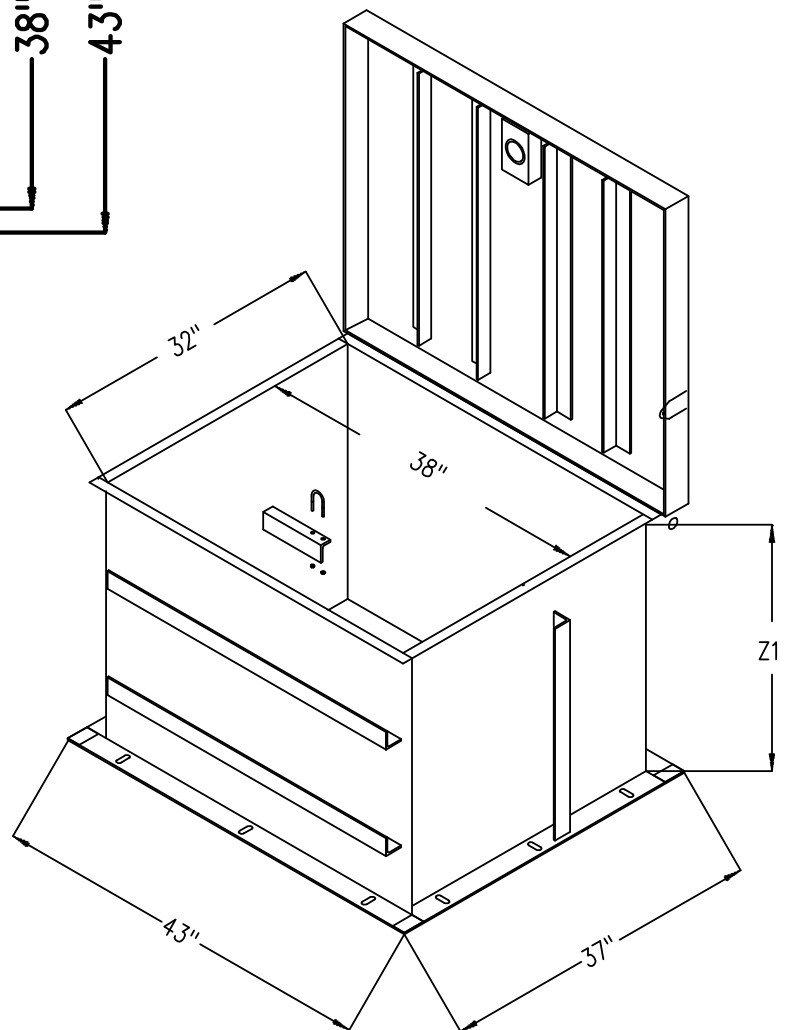

Figure 13
Envelope dimensions

Installation

CAUTION — HEAVY WEIGHT

The riser and ladder assembly weigh several hundred pounds.

It is the responsibility of the installer that proper lifting equipment be used for these procedures and that the installer has sufficient experience, skill, and knowledge to accomplish these tasks safely.

Hatch riser installation

See figures 13 and 14

Ladder installation

See figures 15 and 16

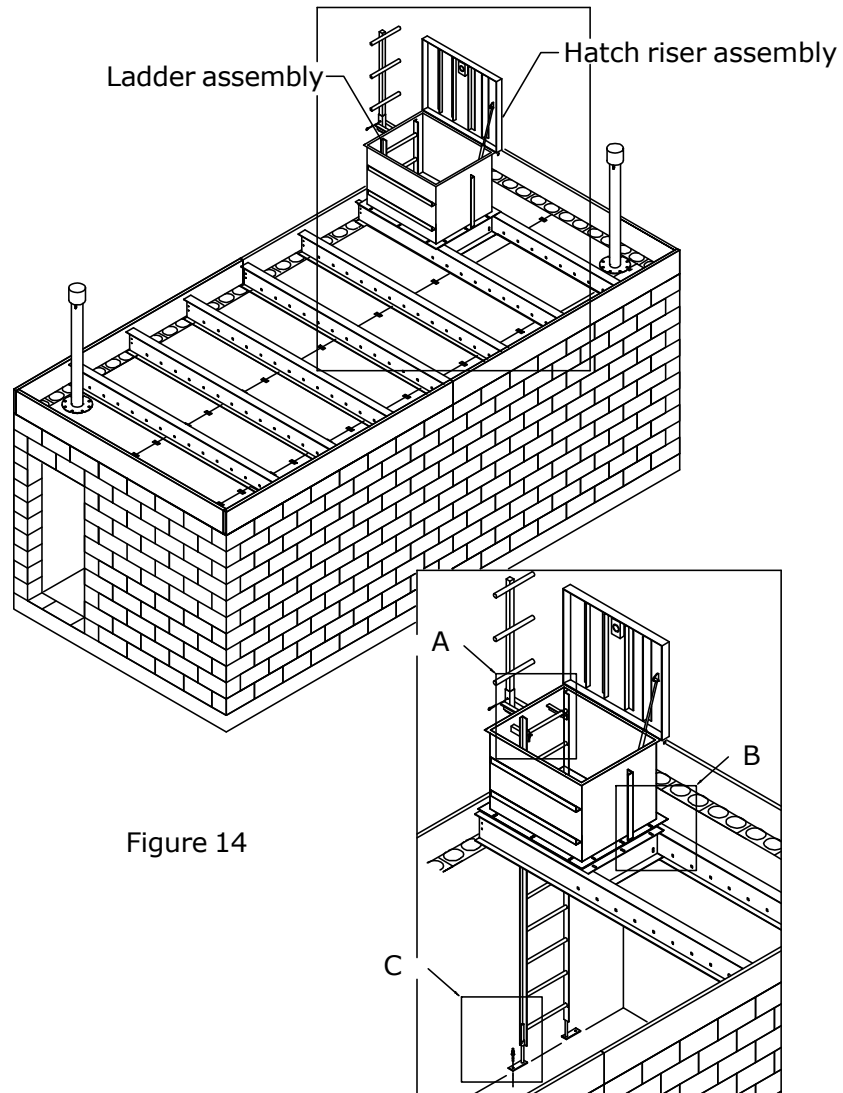

Figure 14

Mounting the riser over the ASR shelter

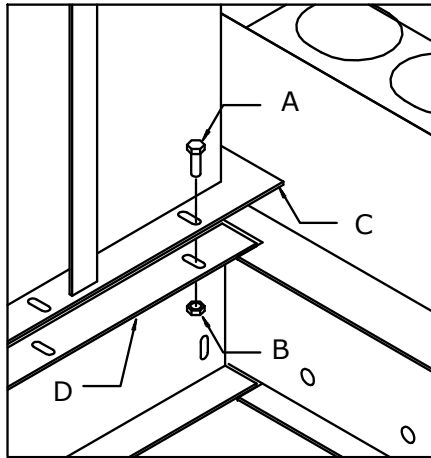

Figure 15

- A. 12 each Bolt 3/8-16 x 1.3/4" length
- B. 12 each Hex nut 3/8-16
- C. Riser mounting flange
- D. Truss mounting flange

This procedure will require the addition of the special riser truss kit, provided with the ASR roof kit.

1. Apply a liberal coat of weather resistant silicone sealant over the edges of the openings surface face where the riser mounting flange bottom face will mate.
2. Install and tighten the provided hex bolts, washers and nuts as shown.

Mounting the riser over conventional concrete shelter

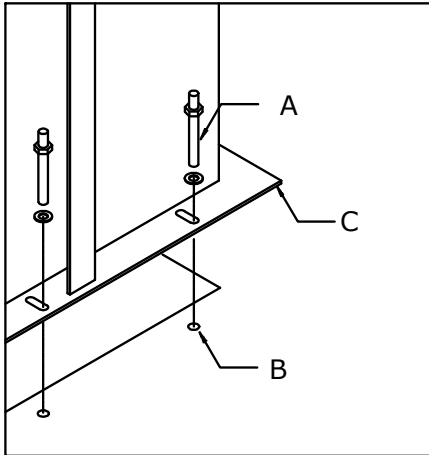

Figure 16

- A. 12 each concrete wedge anchor studs
1/2" X 6" length
- B. 12 each 1/2" drilled hole with provided
masonry drill bit
- C. Riser mounting flange

Please see page 15 for technical
information on these concrete
wedge anchors

This procedure will require the concrete stud anchor kit provided with your concrete style riser and ladder kit order.

1. Using the riser base as a template, locate the drill hole locations for the anchors of the provided stud anchor kit.
2. Remove the riser and drill the holes for the stud anchors.
3. Apply a liberal coat of weather resistant silicone sealant over the edges of the openings surface face where the riser mounting flange bottom face will mate.
4. Replace the riser assembly squarely over the opening and insert the stud anchor assemblies through the riser bottom flange into the drilled hole in the concrete.
5. Tighten all anchor stud nuts to (60 ft-lbs) in a cross pattern.

Note: the concrete opening may not exceed 32" x 38"

Installing the internal ladder assembly

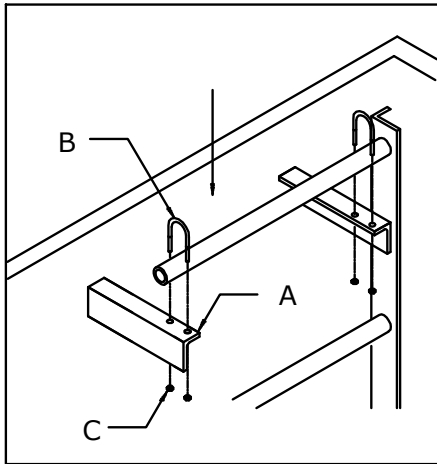

Figure 17

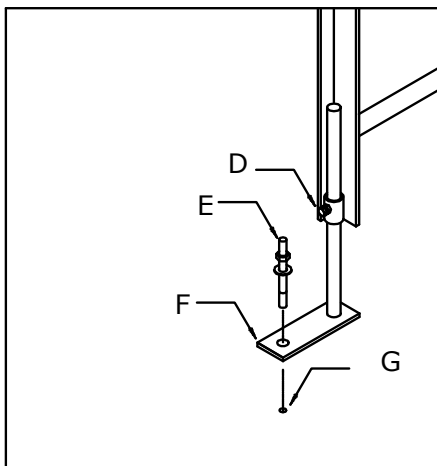

Figure 18

- A. 2 each support brackets
- B. 2 each U-bolts
- C. 4 each hex nuts

- D. 2 each locking bolt
- E. 2 each concrete anchor stud
- F. 2 each drilled holes using provided masonry drill bit

1. Pass the ladder down through the riser opening and rest the second rung on the top support brackets as shown.
2. Insert the provided U-bolts over the ladder rung into and through the support bracket holes and install and tighten provided hex nuts.
3. With the ladder hanging straight loosen the bottom foot locking bolt and lower the mounting foot to the floor and retighten the locking bolt, repeat this procedure for the opposite side.
4. Insure that the ladder is positioned in a true vertical attitude and using the foot as a drill template install the provided anchor stud kit using the same procedure as described above.

Concrete Fastening Systems
Wedge Anchor, Thunder Stud®
1231 E. 26th Street
Cleveland, Ohio 44114

Phone 888-498-5747
Fax 216-357-7435
7:30 – 5:00 Eastern Time

<http://www.confast.com/>

Installing the concrete wedge anchors

Using a ½ inch masonry bit (provided), drill the mounting anchor bolt holes using the pre drilled holes in the frame as a template. See fig. 6.

Included with the hatch are Concrete Wedge Anchor “Thunder Stud®” ½-inch diameter by 4.1/4-inch length and the proper masonry drill bit for these fasteners.

Concrete Wedge Anchor -Technical Information

The ThunderStud® wedge anchor consists of two pieces, permanently pre-assembled into a single unit. The carbon steel rod is threaded for a portion of its length. The extreme end of the threaded portion is rounded to protect the threads from damage while the anchor is being driven into the hole drilled in the concrete. The other end of the rod has a necked down diameter, which runs for a short distance, at the end of which it tapers outwardly to the full diameter of the rod. A precision formed universal clip made of carbon steel is permanently assembled around the necked down diameter to complete the anchor. Each package contains the correct number of nuts and washers.

Concrete Wedge Anchor - Approvals:

Listed by Underwriters Laboratories (UL), International Conference of Building Officials (ICBO) carbon steel only, Board of Standards and Appeals (BSA), City of L.A. Meets or exceeds U.S. Government G.S.A. Specifications FF-S-325 Group 11, Type 4, Class

Concrete Wedge Anchor - Applications:

Medium to heavy duty into concrete.

Concrete Wedge Anchor - Installation:

(1) Drill hole into concrete with a carbide tipped masonry drill bit conforming to ANSI B94, 12-77, the same size as the ThunderStud® wedge anchor. If the fixture being fastened is in place and being used as a template to locate the ThunderStud® anchor, the mounting hole in the fixture should afford clearance for the universal wedge clip on the stud. (2) Clean hole, place the ThunderStud® wedge anchor through the hole in the fixture or directly into the concrete and hammer it in to the drilled hole until the threads are below the surface of the fixture/concrete. (3) Turn the nut by hand until the unit is snugged up. Tighten the nut with a wrench, approximately three or four full turns, to complete the fastening.

Concrete Wedge Anchor - Anchor Length:

Minimum embedment, plus fixture, plus nut and washer. The ThunderStud® wedge anchor requires no maximum hole depth. The depth of the hole in the concrete should be the length of the wedge anchor minus the thickness of the material being fastened. This will result in some extra depth to accommodate a minor amount of concrete cutting which may not be able to be cleaned out of hole.